

MIXCORE



MIXCORE SERIES

Vacuum Homogenizing & Mixing Plant

for the personal care, cosmetic, pharmaceutical, chemical and food industry

Vacuum Homogenizing & Mixing Plant

Mixing + Homogenizing = MixCore

This is the formula for your success! MixCore systems technology offers all functions for the production of complex products for many industries – from laboratory to production scale.

Due to its wide ranges of features its ideal for the manufacture of different products with a wide variation of processing requirements. All semi-solid products such as suspensions, creams, emulsions, and gels can be reliably manufactured in a fast and efficient way. Even a sterile version of the MixCore is available.

MixCore Vertical (MC-V)



MixCore Horizontal (MC-H)

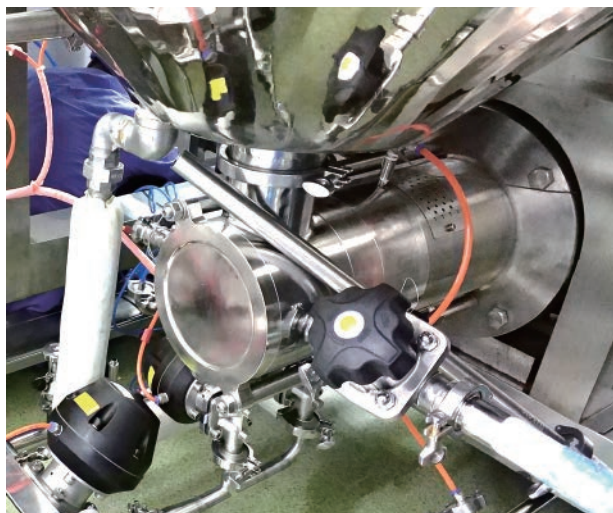

Standard version

- Mixing vessel with safety device and scraper agitator
- Double jacket for heating and cooling
- Powerful vacuum system
- Rotor-stator homogenizer with pumping function
- Temperature control
- User friendly interface
- External and internal recirculation line
- CIP capability

Options

- Vertical or horizontal homogenizer arrangement
- Direct steam injection for accelerated product heating
- Two automation levels
- Product feed via weighing system of a flow meter, load cells or dosing station
- Shaft seal or mechanical seal concepts
- Sterile versions
- Comprehensive validation documentation
- Other options on request

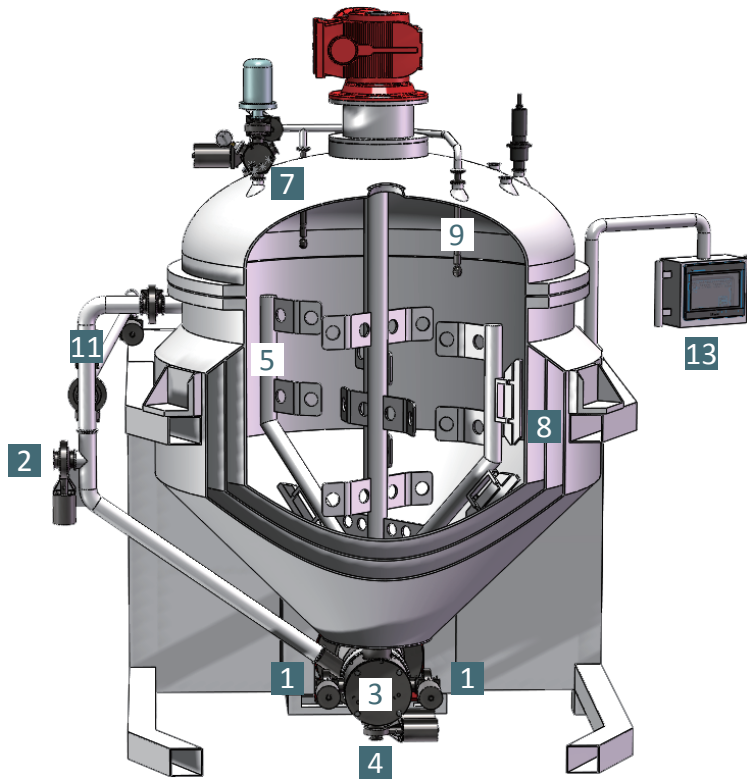

Applications

- > Creams
- > Gels
- > Ointments
- > Skin care
- > Suspensions
- > Shampoo
- > Natural cosmetics
- > Sun lotions
- > Toothpaste
- > Color cosmetics
- > Sauces
- > Dressings
- > Mayonnaise
- > Ketchup
- > Liquid spices
- > Cheese spread
- > Baby food
- > Jams
- > Pet food
- > And many more

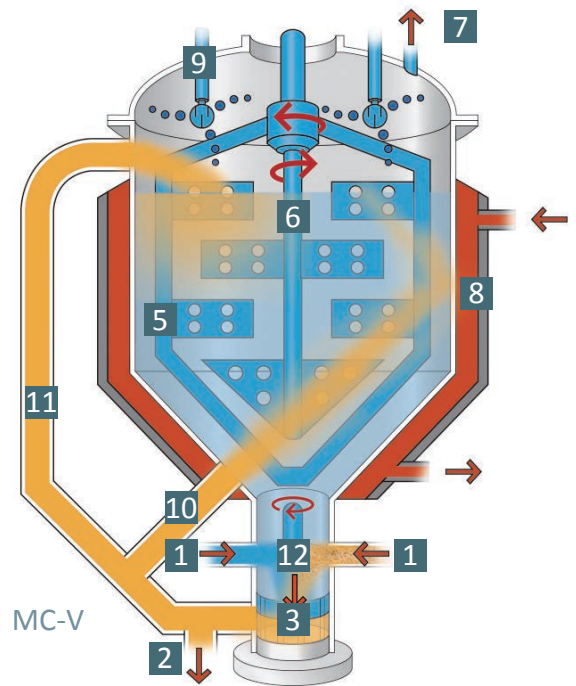
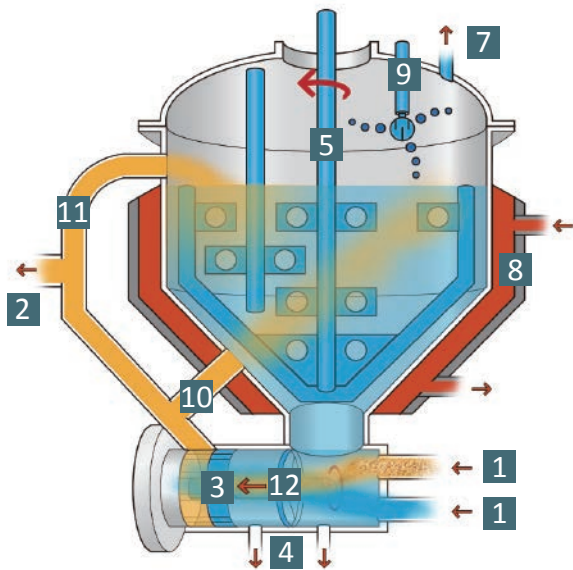

- 1 Raw materials infeed
- 2 Product discharge
- 3 Homogenizer
- 4 Residue discharge/CIP recirculation
- 5 Scraper agitator
- 6 Center rotating agitator
- 7 Vacuum system
- 8 Heating/cooling
- 9 CIP
- 10 Internal loop
- 11 External loop
- 12 Premix
- 13 HMI

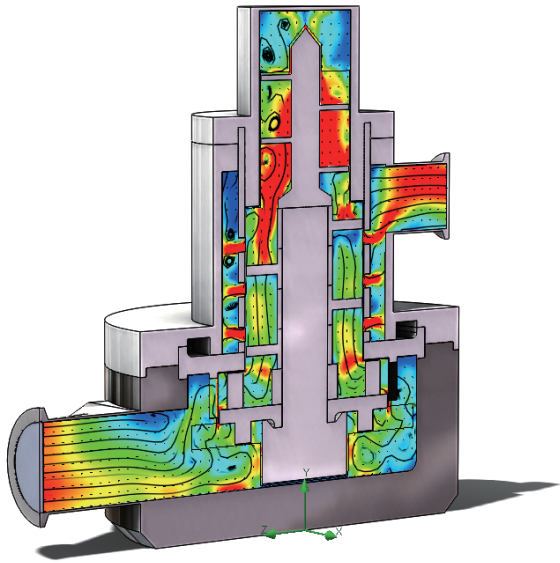

SIMULATION OF FLUID
DYNAMICS BY CFD

Key Benefits

- Unique mixing and homogenizing system
- Dust-free feeding of powders
- Fastest dispersing of powders and de-aeration
- Reduction of production times up to 60%
- Highest yield rates because of internal and external circulation
- Short discharge and cleaning times
- Aseptic design for fast and efficient cleaning
- Can handle highest viscosities up to 80.000mPas
- Ergonomic operation and handling
- Can make full size batches or as little as 1/4 size batches

Three alternative agitator geometries



For simple applications we can provide you with a more cost-effective solution

For more information, please see MixCore Lite's booklet.

Technical Data

MIXCORE MC-H

Type	15	50	100	250	650	1300	1800	2400
Working Volume (L)	12	40	80	200	500	1000	1500	2000
Power (kW)	9	15	15	26	26	45	45	53
Length A (mm)	1400	1400	1600	2000	2300	3000	3000	3100
Width B (mm)	900	1500	1500	1750	1900	2100	2100	2300
Height C(mm)	1600	1800	2100	2300	2700	3100	3400	3700
Height D*(mm)	1650	2100	2250	2500	2900			

*with open lid

MIXCORE MC-V

Type	15	50	100	250	650	1300	1800	2400
Working Volume (L)	12	40	80	200	500	1000	1500	2000
Power (kW)	9	15	15	26	26	45	53	58
Length A (mm)	1030	1250	1400	1900	2400	2500	2800	3000
Width B (mm)	800	1050	1200	1500	1500	1600	1800	2000
Height C(mm)	1300	1700	2200	2700	3000	3600	3600	4000
Height D*(mm)	1700	2050	2700	3400	3900	4800	4800	5000

*with open lid

MC-H

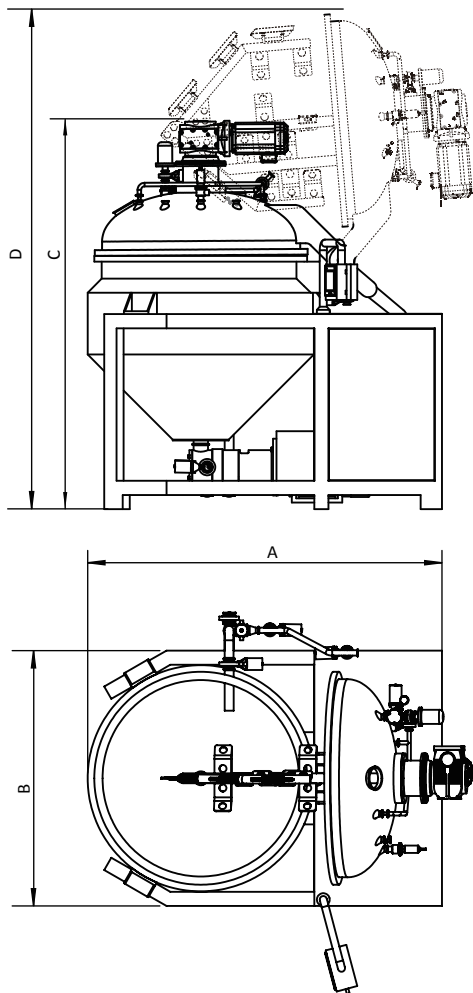

MC-V

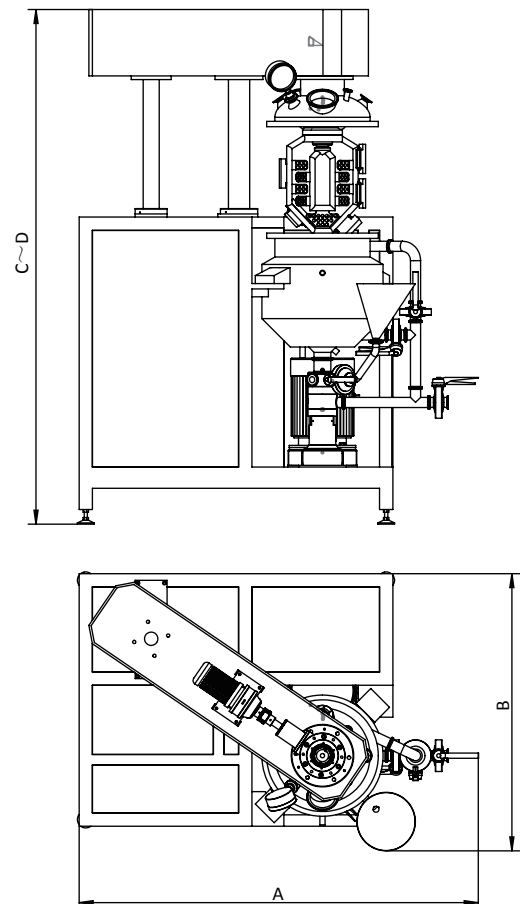



Founded in 1998, Wuxi YK Automation Technology Co., Ltd. has developed from a micro-factory with the initial registered capital of RMB one million to an enterprise which owns 3 subsidiaries--Wuxi Jianuo Delicate Chemical Equipment Factory, Guangzhou Jianuo Machinery Equipment Co., Ltd. and Wuxi Jianuo Commercial Trade Co., Ltd. YK is specialized in designing, developing and manufacturing mixers and filling machines. Up to now, we have developed various world's leading machines which sell well both in domestic and international market.

As a leader in domestic mixer and filling equipment industry, we provide competitive solutions and service for pharmaceutical, cosmetic, food and chemical enterprises. Every year, we devote over 10% of sales to research and development. And our R&D team is set up by undergraduate and graduate students, foreign specialists and senior engineers, with distinguished design, R&D capacities. Until now, we have got 38 patents.

Wuxi YK Automation Technology Co.,Ltd

No.2855 Jiaoyang Road, An Zhen, Wuxi, Jiangsu, China

Phone: +86-510-88530355 / 88789555

Email: sales@yk-machine.cn

www.yk-machinery.com